

WA7305-2S DOUBLE TOILET ROLL HOLDER

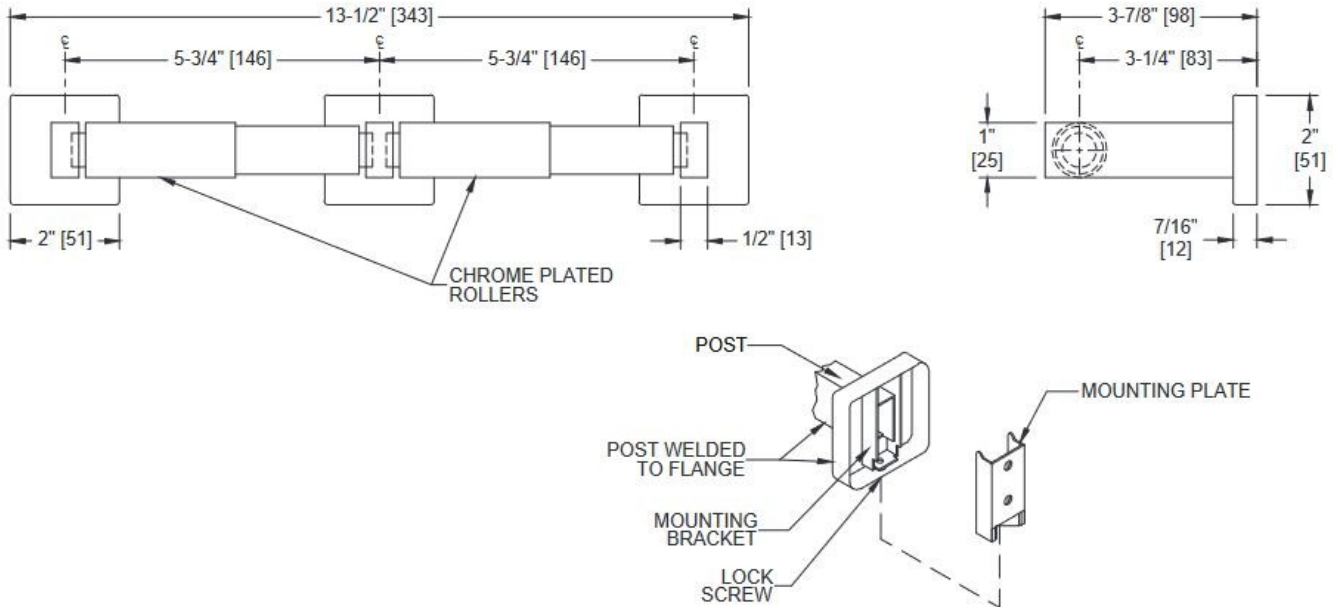

Description

- Model WA7305-2S is our double toilet roll holder with spring loaded chrome plated spindles
- Manufactured from grade 304 satin finish stainless steel
- Wall mounted design with concealed wall brackets/wall plates
- Can hold two standard toilet rolls up to 140mm diameter

Dimensions

- **Length (including wall plates):** 343mm
- **Spindle length:** 146mm
- **Projection:** 98mm

Delivery

- From stock, usually 1 to 3 working days